

# FILTERS SERIES MAF302, MAF401, AND MAF501

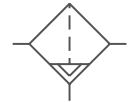

Primary air particulate filters are designed to separate liquid, water, rust, pipe scale, and debris from air lines. They should be installed upstream of the regulator and/or lubricator to prevent contamination from reaching other components.

Series 401 has got metal bowl with sight glass and series 302 and 501 have got polycarbonate or nylon bowl with plastic guard or metal bowl.



Port thread	MAF302			MAF401			MAF501	
	G1/4"	G3/8"	G1/2"	G1/4"	G3/8"	G1/2"	G3/4"	G1"
Flow at 0,7 MPa ( $\Delta p=0,03\text{MPa}$ ) [NI/min]	910	1100	1100	1300	2000	2500	7000	7000
Primary pressure [MPa] for semiautomatic drain	0,05 to 1			0,05 to 1,5			0,05 to 1 and 0,05 to 1,5 for metal bowl	
Primary pressure [MPa] for automatic drain	0,15 to 1			0,15 to 1			0,15 to 1	
Test pressure [MPa]	1,5			2			1,5, 2 for metal bowl	
Temperature range [°C]	-5 to +60			-5 to +60			-5 to +60	
Filter element [ $\mu\text{m}$ ]	5			40			40	
Weight [kg]	0,34			0,48			1.18, 1.30 for metal bowl	
Supply contains	bracket (C-shaped)			bracket (C-shaped)			bracket (elbow)	

## Order codes

PMAF401-10A – 5u – BSP

Port size	
401-8A	G1/4"
401-10A	G3/8"
401-15A	G1/2"

Condensation draining	
–	semiautomatic
D	automatic

PMAF501-20A M – BSP

Port size	
302-8A	G1/4"
302-10A	G3/8"
302-15A	G1/2"
501-20A	G3/4"
501-25A	G1"

Bowl	
	polycarbonate
N	nylon
M	metal

Condensation draining	
–	semiautomatic
D	automatic

**i** Semiautomatic condensation draining automatically drains when the primary pressure drops under 0,05 MPa.

## Flow capacity

Flow rates at primary pressure 0,7 MPa

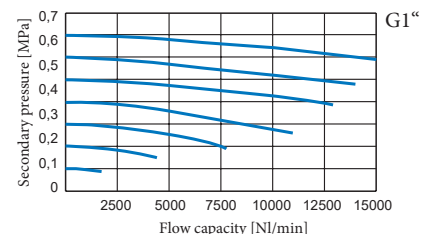
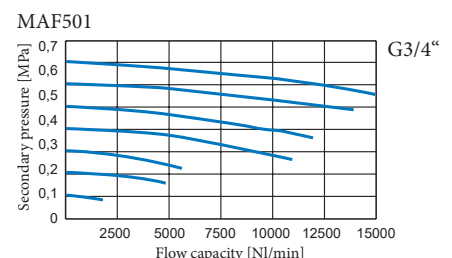
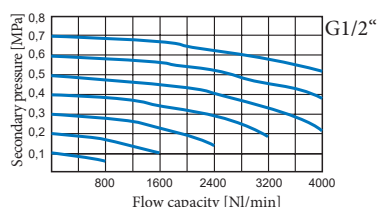
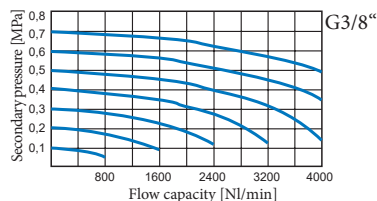
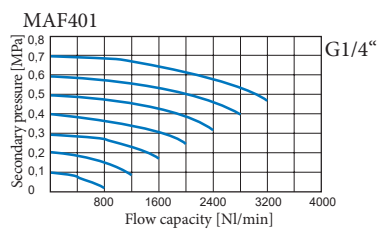
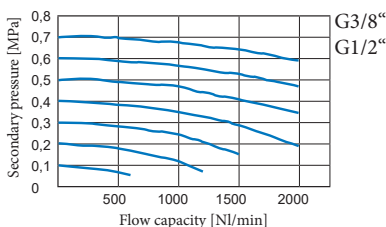
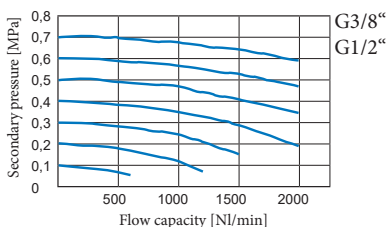
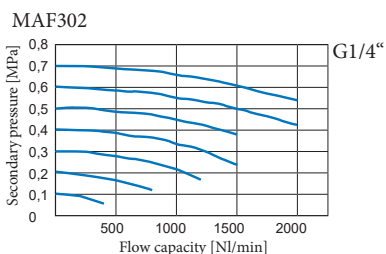

## Dimensions

MAF302

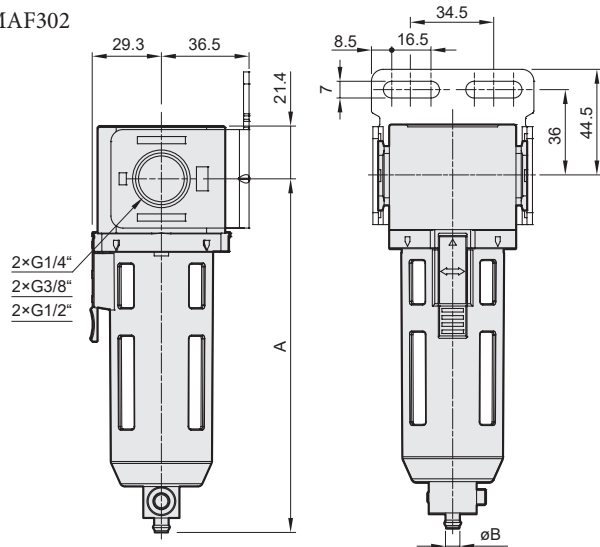

Semiautomatic condensation draining

Bowl	A	B - inner tube ø
polycarbonate	147,1	6
nylon		
metal	147,2	5

Automatic condensation draining

Bowl	A	B - outer tube ø
polycarbonate	156,6	8
nylon		
metal	159,1	8

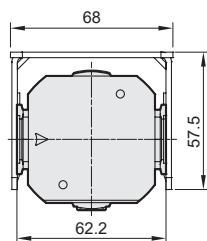

MAF401

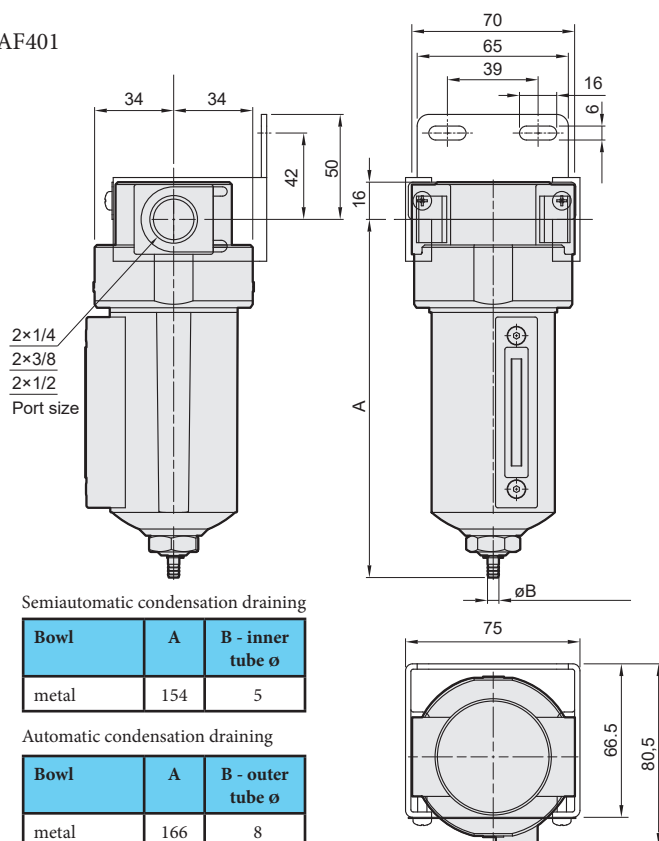

Semiautomatic condensation draining

Bowl	A	B - inner tube ø
metal	154	5

Automatic condensation draining

Bowl	A	B - outer tube ø
metal	166	8

MAF501

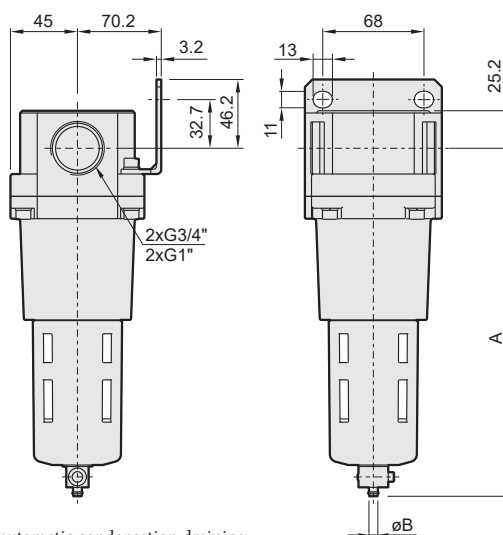

Semiautomatic condensation draining

Bowl	A	B - inner tube ø
polycarbonate	233,8	6
nylon		
metal	231,4	5

Automatic condensation draining

Bowl	A	B - outer tube ø
polycarbonate	243,3	8
nylon		
metal	243,3	8

