

Soft start-up valve is used everywhere, where items in line behind the valve should be secured against intense pressure rise after connection to air supply, as is common when hand valve or quick connect couplings are used. When the valve is energized or manually operated, output pressure will increase gradually with flow rate, which can be adjusted. After specific pressure (see chart) is reached, full pressure and flow is switched to output. When the valve is de-energized or switched off manually, input is closed and air from the line will be quickly exhausted.

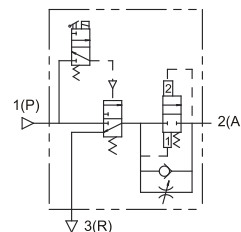

Port size	G1/2 <sup>c</sup>
Flow at 0.7 MPa ( $\Delta p=0.03\text{MPa}$ ) [Nl/min]	3000 in direction 1(P) $\rightarrow$ 2(A); 3800 in direction 2(A) $\rightarrow$ 3(R)
Primary pressure [MPa]	0.25 to 1.0
Temperature range [°C]	0 to +60
Power input [VA / W]	inrush 6, hold 4.9 for AC; 2.5 for DC
Insulation class	F
Weight [kg]	0.8
Supply contains	with connector, optionally with gauge, bracket on request

## Order codes

PMAVS4001 C D24 L

Gauge	
	without gauge
C	with gauge

Voltage	
D24	24 V DC $\pm$ 10%
A220	230 V AC $\pm$ 10%, 50-60 Hz
A24	24 V AC $\pm$ 10%, 50-60 Hz

Connector	
	standard
L	with LED

**i** Valve can be used standalone, or should be attached using connection plate (order code PMACP401-C) with other units of series 401.

**i** The total effective orifice of piping and components on the P port side must be equal or larger than 35 mm<sup>2</sup>. When the air current is restricted or insufficient pressure, the main valve will not function / switch normally and it could cause air to leak from the R port.

## Dimensions

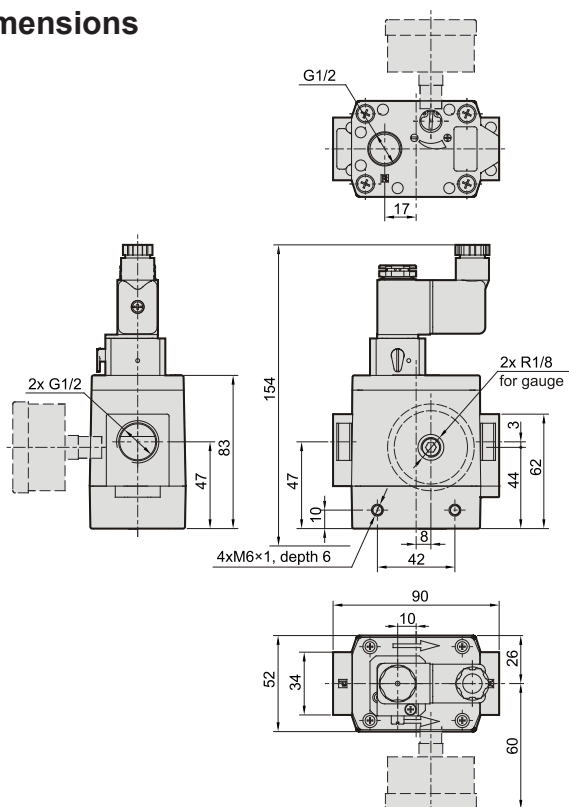

## Full pressure and flow capacity switching point

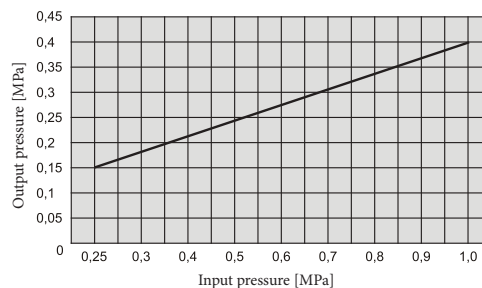

## Slow start-up flow capacity characteristics

