

DOUBLE ACTING PNEUMATIC CYLINDERS WITH LOCK DEVICE VDMA 24562, NF E 49003.1



Cylinders are designed to meet the specifications of international standard VDMA 24562 for mounting. The cylinders can work in higher temperatures by request. Fully adjustable cushioning at end of stroke is available. Lock device is actuated by spring force and deactivated by compressed air. Lock device is self-locking.

Lock device is not a safety element! The user must take relevant safety precautions!



Warning

Clamping force is purely static. When exceeding load, slipping of piston rod may occur, or piston rod and/or lock device can be damaged. Right connection and suitable designed control is necessary for impact free work. Please consult your connection with our technical dept.

Working pressure	0.6 MPa
Min. pressure	0.15 MPa
Max. pressure	1.0 MPa
Min. pressure for lock release	0.2 MPa
Locking direction	both direction
Temp. range	-20°C to +80°C *
Working medium	modified compressed air

*) values are valid for standard gaskets

Piston diameter [mm]	32	40	50	63	80	100	125
Thrust at 0.6 MPa [N]	482	754	1178	1870	3015	4713	7363
Thrust at 0.6 MPa [N] with double ended piston rod	415	633	990	1682	2720	4418	6880
Return force at 0.6 MPa [N]	415	633	990	1682	2720	4418	6880
Static clamping force [N]	>482	>754	>1178	>1870	>3015	>4713	>7363
Connection	G1/8"	G1/4"	G1/4"	G3/8"	G3/8"	G1/2"	G1/2"
Length of adjustable cushioning [mm]	13	13	11	16	16	20	25
Max. stroke [mm] *	1000*	1000*	1000*	1000*	1000*	1000*	1500*
Weight 0 mm stroke [kg]	1.15	1.62	2.80	3.90	6.20	9.80	20.6
Weight add. per 1 mm stroke [kg]	0.0028	0.0037	0.0060	0.0062	0.0100	0.0110	0.0160
Weight 0 mm stroke [kg] with double ended piston rod	1.25	1.72	3.00	4.10	6.90	10.60	22.4
Weight add. per 1 mm stroke [kg] with dbl. ended piston rod	0.0038	0.0047	0.0080	0.0082	0.0140	0.0150	0.0220

*) Stroke of cylinder may be longer after agreement with our technical dept.

Order codes

10110 60 00 050 0100

Type		Equipment		Options		Piston diameter		Stroke / Repair kit	
10110	DIN ISO 6431, VDMA 24562, NF E 49003.1, double acting, with lock device	00	w/o cushioning, w/o magnet	00	without options	032	32 mm	xxxx	mm of stroke e.g.: 0100 = stroke 100 mm
		05	double ended piston rod, w/o cushioning, w/o magnet	10	Viton® piston rod sealing	040	40 mm	9999	repair kit
		10	w/o cushioning, with magnet	11	Viton® gaskets (up to 180°C)	050	50 mm		
		15	double ended piston rod, w/o cushioning, with magnet	13	round tube*	063	63 mm		
		50	with cushioning, w/o magnet	14	1.4301 stainless steel piston rod	080	80 mm		
		55	double ended piston rod, with cushioning, w/o magnet			100	100 mm		
		60	with cushioning, with magnet			125	125 mm		
		65	double ended piston rod, with cushioning, with magnet						

*) Only valid for piston dia. 32 to 100 mm included

For more options regarding materials or dimensions, please contact our technical dept.

Construction / materials

- caps: drawn dural profile, anodised, piston dia. 100: aluminium casting, anodised
- body: drawn dural profile, anodized
- piston rod: ground round steel bar CK45 with hard chrome plated surface

Dimensions

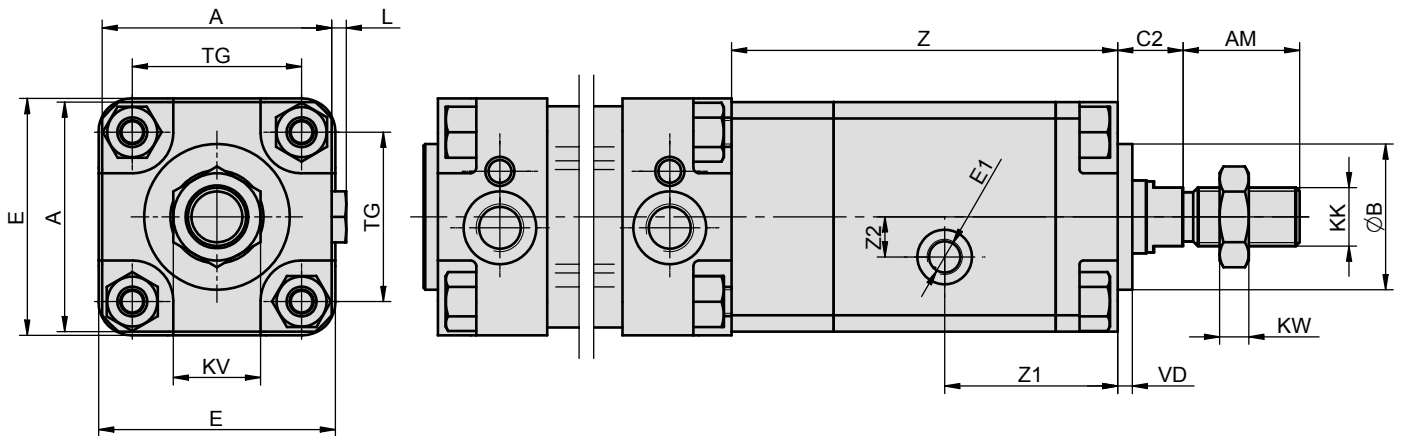

∅	A	AM	B	C2	E	E1	KK	KV	KW	L	TG	VD	Z	Z1	Z2
32	45	22	30	13.5	48	G1/8"	M10x1.25	16	5	4	32.5	4	95	47	5
40	56	24	35	16	55	G1/8"	M12x1.25	18	6	4	38	4	107	49.5	9
50	63	32	40	18	65	G1/8"	M16x1.5	24	8	4	46.5	4	106	46.5	11
63	70	32	45	18	75	G1/8"	M16x1.5	24	8	4	56.5	4	116	52.5	11
80	90	40	45	18	94	G1/8"	M20x1.5	30	10	5	72	5	150	65	18
100	110	43	55	18	115	G1/8"	M20x1.5	30	10	5	89	5	158	66.5	18
125	140	54	60	22	140	G1/4"	M27x2	30	13	-	110	5	255	106	0

For dimensions of pneumatic cylinder on which the lock device is attached, see page 2-5

Connection example for pushbutton control:

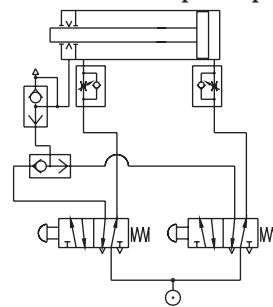

Pressing the left pushbutton, the lock unit will unclamp and air which flows through right push-button into cylinder will extend it. After release pushbutton, compressed air is released from lock unit, which clamps piston rod and cylinder stops. For quick stopping of cylinder, the quick exhaust valve is used. The im-

portant on this connection is, that both chambers of cylinder are still with compressed air and for motion control discharging of air from particular chambers is used, which prevents from impacts or unwanted counter-movements.

Mounting accessories

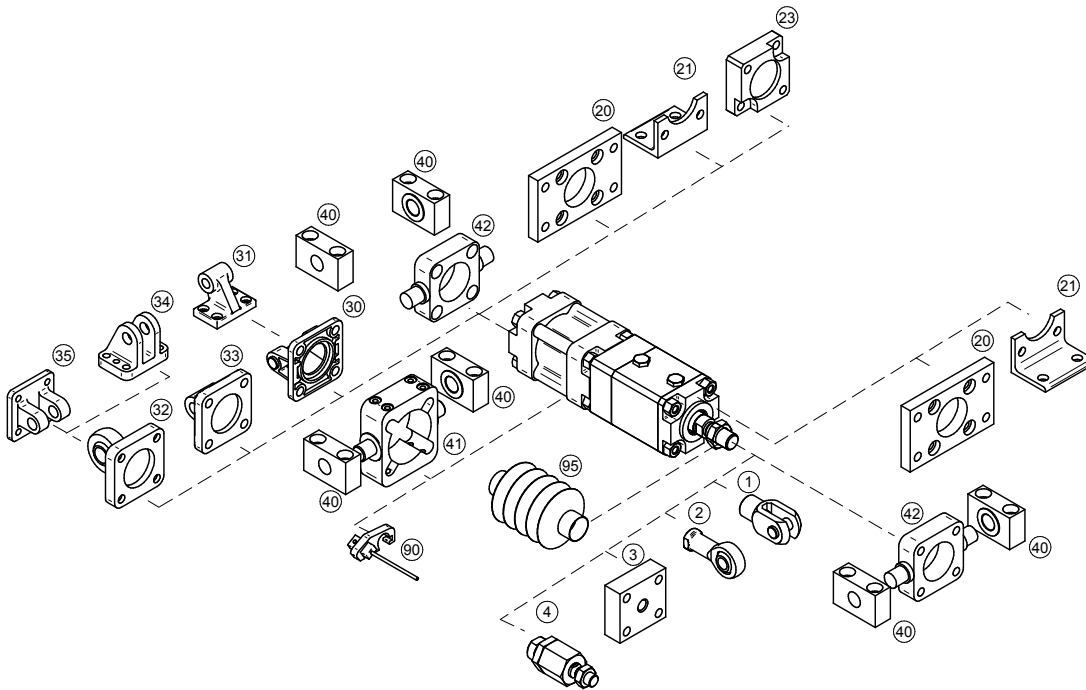

Mounting accessories	... see page
1 Piston rod clevis	... 4-2
2 Piston rod eye	... 4-3
3 Flanged piston rod coupling	... 4-2
4 Self-aligning piston rod coupling	... 4-3
20 Flange mounting	... 4-6
21 Foot mounting	... 4-4
23 Boxer flange mounting	... 4-22
30 Swivel flange	... 4-8
31 Clevis foot mounting	... 4-8
32 Swivel flange with spherical bearing	... 4-10
33 Swivel flange	... 4-7
34 Narrow swivel flange	... 4-9
35 Rectangular swivel flange	... 4-9
40 Trunnion mounting	... 4-12
41 Pivot pin	... 4-11
42 Pivot pin to front/end cap	... 4-12
90 Prox. switch	... 3-2, 3-4, 3-7
95 Piston rod protective cover	... 4-23