

# DOUBLE ACTING PNEUMATIC CYLINDERS SERIES MCGD TWIN GUIDE, SLIDE

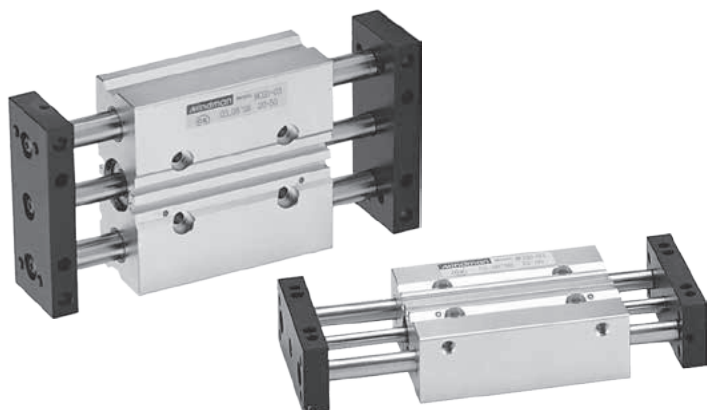

Cylinders series MCGD can be used as cylinders with slide plates or body slide. Cylinders series MCGD are designed as compact makes the cylinder working more smoothly and showing the characteristics of its high-strength and high-stiffness. Cylinders are equipped with magnet for proximity switches. The recessed groove for sensor switch keeps space saving and interference is avoided. The body and plate are reserved with many holes and threads for mounting. It is suitable for various mounting requirement. There is no adjustable cushioning, for cushioning at the end positions the rubber pad is used.

Working pressure	0.6 MPa
Min. pressure	0.1 MPa
Max. pressure	1.0 MPa
Temp. range	-5°C to +60°C
Working medium	modified compressed air

Piston diameter [mm]	12	16	20	25	32
Thrust at 0.6 MPa [N]	50	102	158	248	415
Return force at 0.6 MPa [N]	50	102	158	248	415
Connection	M5	M5	G1/8"	G1/8"	G1/8"
Max. stroke [mm]	100	150	150	150	250

## Order codes

P MCGD 03 12 50

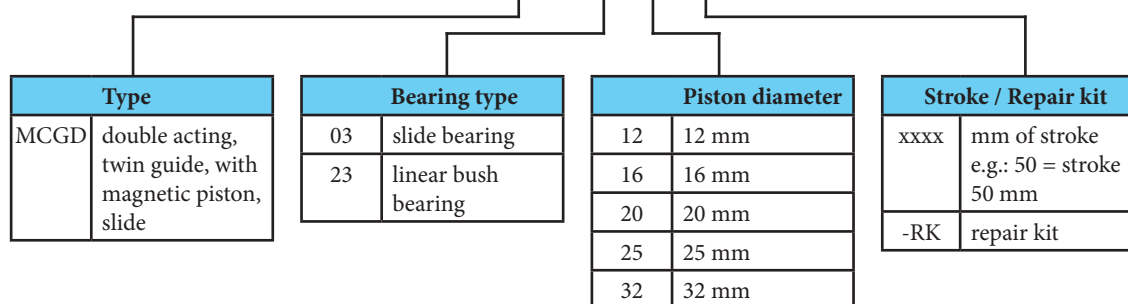

### Installation of proximity switch

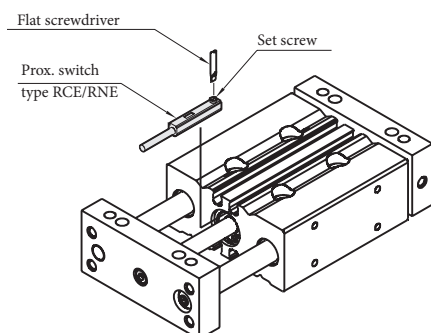

Piston dia. [mm]	Bearing type	Standard stroke [mm]*								
		30	50	75	100	125	150	175	200	250
12	03	•	•	•	•					
16, 20, 25		•	•	•	•	•	•			
32		•	•	•	•	•	•	•	•	•
12	23	•	•	•	•					
16, 20		•	•	•	•	•				
25			•	•	•	•				
32			•	•	•	•	•	•	•	•

\*) Please consult us if stroke is out of specification

## Construction / materials

- caps: aluminium alloy
- body: aluminium alloy
- piston rod: carbon steel
- guide rods: carbon steel for slide bearing, bearing steel for linear bush bearing
- plate: aluminium alloy
- bearing: copper for slide bearing, linear bush bearing

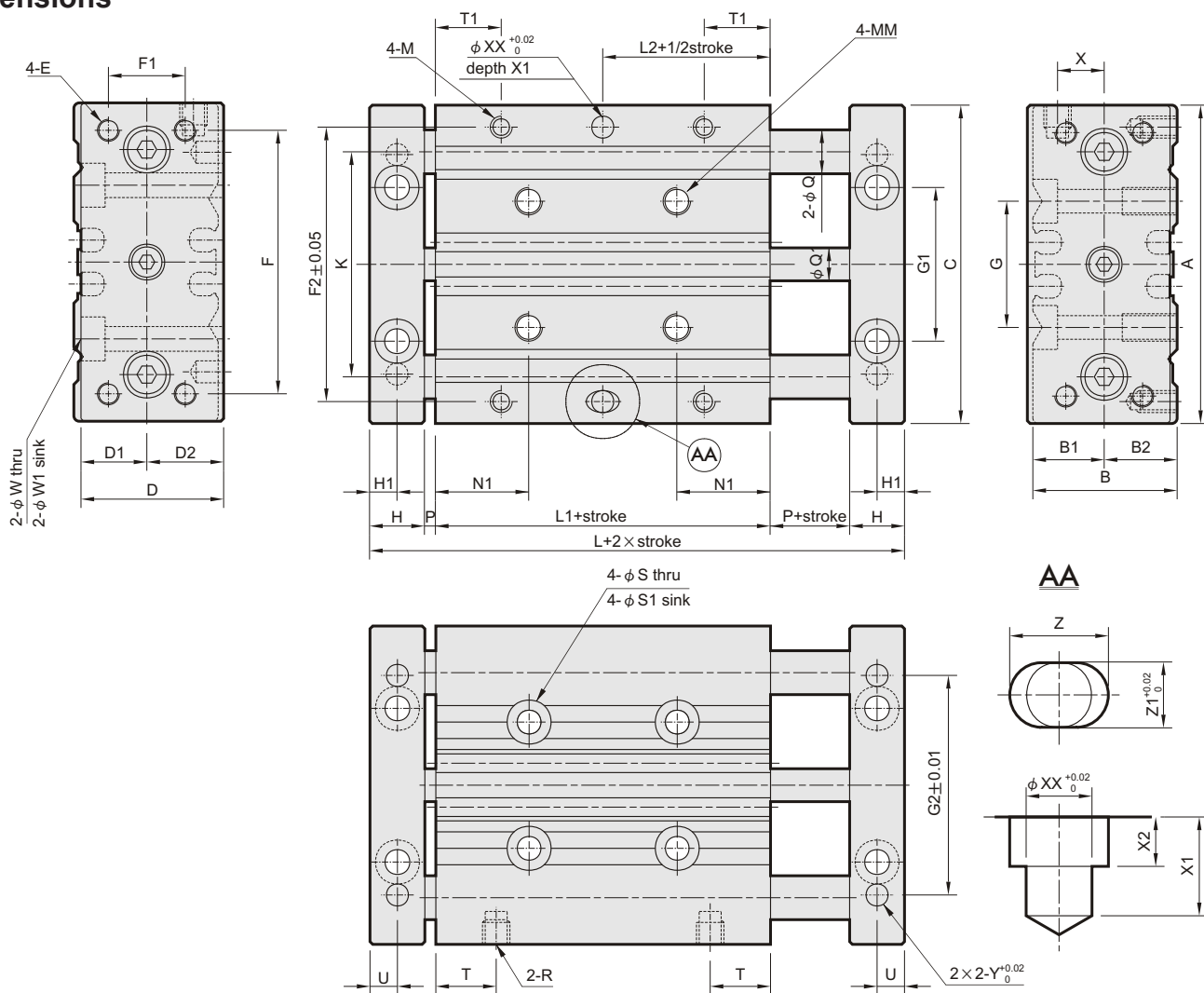

In case of proximity sensing request, please use switches series RCE/RPE/RNE - see page 3-8 for detail

**Dimensions**

∅	A	B	B1	B2	C	D	D1	D2	E	F	F1	F2	G	G1	G2	H	H1	K	L	L1	L2	M	MM	N1	Q (type 03)	Q (type 23)	Q1	P	R
12	58	26	13	13	58	26	12	14	M4	48	14	50	23	28	40	10	5	41.5	55	31	15.5	M4 dp. 7	M5 dp. 10	17	8	6	2	M5	
16	64	30	15	15	64	30	14	16	M5	52	16	54	24	32	50	12	6	46	62	34	17	M5 dp. 7	M5 dp. 10	17	10	8	2	M5	
20	85	36	19	17	85	36	16	20	M5	60	18	64	28	37	70	12	6	55	66	38	19	M5 dp. 7	M6 dp. 12	20.5	12	10	2	G1/8"	
25	96	42	21	21	96	42	20	22	M6	70	26	76	34	44	84	12	6	65	67	39	19.5	M6 dp. 9	M6 dp. 12	19.5	16	13	2	G1/8"	
32	116	51	25	26	116	51	24	27	M8	96	30	100	42	56	76	14	7	80	68	36	18	M8 dp. 11	M8 dp. 16	20	20	16	2	G1/8"	

∅	S	S1	T	T1	U	W	W1	X	XX	X1	X2	Y	Z	Z1
12	4.3	8 dp. 4.5	11	12	5	4.5	8 dp. 4.5	8.5	4	6	3	∅4 dp. 5	6	4
16	4.3	8 dp. 4.5	11	13	6	4.5	8 dp. 4.5	10	5	6	3	∅5 dp. 5	7	5
20	5.2	9.5 dp. 5.5	13.5	14	6	5.5	9.5 dp. 5.5	11.5	6	8	4	∅6 dp. 8	8	6
25	5.2	9.5 dp. 5.5	11	12	6	5.5	9.5 dp. 5.5	13.5	6	8	4	∅6 dp. 8	8	6
32	6.8	11.5 dp. 6.5	11	16.5	7	6.6	11 dp. 6.5	16	8	12	6	∅8 dp. 12	10	8