

SERVICE MANUAL

Electro-Pneumatic Regulator

MAER200 series

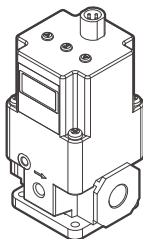

Order example

MAER200 – 8A – 9K – 111 – B1 – S1 – G

①

②

③

④

⑤

⑥

⑦

- | | | | | |
|-------------|------------------|----------------|--------------------|------------------|
| ① Model | ③ Pressure range | ⑤ Bracket | ⑥ Cable connector | ⑦ Port thread |
| ② Port size | Blank: Without | Blank: Without | Blank: Without | Blank: Rc thread |
| 8A: 1/4 | 1K: 0.1 MPa | B1: L type | S1: Straight 1m | G: G thread |
| 10A: 3/8 | 5K: 0.5 MPa | B2: Flat type | S3: Straight 3m | NPT: NPT thread |
| | 9K: 0.9 MPa | | L1: Right angle 1m | |
| | | | L3: Right angle 3m | |

④ Signal input	Signal output	Pressure display unit
1: Current DC4~20mA 2: Voltage DC0~10V 3: Voltage DC0~5V	1: Analog output DC1~5V 2: Switch output NPN 3: Switch output PNP 4: Analog output DC4~20mA (Source type)	1: MPa 2: kgf/cm ² 3: bar 4: psi 5: kPa
40: Preset input	—	

Precaution

To ensure safe operation, please read this service manual carefully before use. When designing and manufacturing equipment using Mindman products, the manufacturer is obligated to ensure that the safety of the mechanism, pneumatic control circuit and/or air control circuit and the system that runs the electrical controls are secured.

Explanation of label

Observe the warnings and cautions on the following pages to prevent accidents. These instructions indicate the level of potential hazard by labels of "WARNING" or "CAUTION". Note that some items indicated with "CAUTION" may lead to serious results depending on the conditions. All items contain important information and must be observed.



WARNING

A dangerous situation may occur if handling is mistaken, leading to fatal or serious injuries.

- ① Let the designer of pneumatic system or rule tester to determine if this direction control valve is suitable or not.
- ② The product must be operated by the person who has professional knowledge and practical experience.
- ③ Please confirm product specifications before use. Do not use input signal exceeding specifications. This product could malfunction fire if input signal exceeding the working range is applied.
- ④ If an abnormality occurs during operation, immediately turn off the power and air pressure and stop using it.
- ⑤ This product is adjusted for each specification at the time of shipment from the factory. Disassemble and reformation are prohibited, as this way might lead to malfunction.



CAUTION

A dangerous situation may occur if handling is mistaken, leading to minor injuries or property damage.

- ① Avoid using this regulator where it will be subject to direct sunlight, water or oil, etc.
- ② Use in place where the temperature changes drastically or at high humidity may cause damage due to dew condensation in the product.
- ③ If supply pressure to this product is interrupted while the power is still on, the inner solenoid valve will continue to operate and a humming noise may be generated. Since the life of the product may be shortened, shut off the power supply also when supply pressure is shut off.
- ④ If electric power is shut off while pressure is being applied, the output pressure will be retained. However, this output pressure is held only temporarily and is guaranteed.

Precaution

- ⑤ The product characteristics are confined to no flow in the pipeline. When air is consumed on the output side, pressure may become unstable.
- ⑥ In order to avoid the error caused by noise, please take the following measures:
 - a Set the line filter on AC power line to remove the power noise.
 - b Keep the product away from the engine and power line to avoid noise affects.
 - c Induced charge (like solenoid valve, relay), must prevent them from negative charge.
 - d In order to avoid the effects of power fluctuation, please cut off the power before plug the connector.
- ⑦ The cable plug is four-core wire. When the monitor output is not being used, prevent it from touching the other wires as this can cause a malfunction.
- ⑧ Please note that the right angled cable connector does not rotate and is limited to only one entry direction.
- ⑨ Use clean compressed air that does not contain corrosive gas. Poor air quality adversely affects function and life.
- ⑩ Do not use a lubricator on the supply side of this product, the lubricated air might cause malfunction. When lubrication of terminal equipment is necessary, connect a lubricator on the output side of the equipment and set a check valve. When the secondary pressure is lowered with an input signal, etc., the secondary air passes through the product and is discharged from the EXH port. Contamination on the secondary piping and the inside of the load will have an adverse effect on performance, etc. Keep the inside of the piping as clean as possible.
- ⑪ When supplying compressed air for the first time after connecting pipes, confirm that no air is leaking from any pipe connections.
- ⑫ Tighten pipes with the appropriate torque to prevent air leakage and screw damage. First tighten the screw by hand to prevent damage to screw threads, then use a tool.
- ⑬ For the pneumatic source, use cleaned air from which the solid, water and oil contents were eliminated sufficiently, using an air dryer, filter and oil mist filter. Recommend selecting a filtration precision of $5\mu\text{m}$ or less.

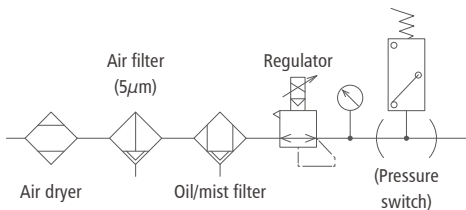

Application of proportional pressure controls

Controlling pressure for painting

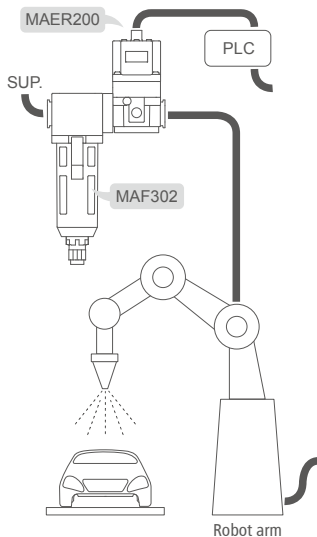

Controlling pressure for grinding force

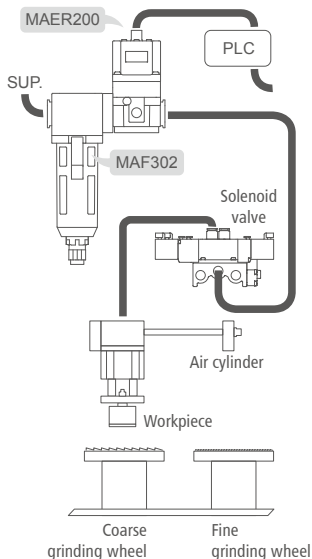

Wiring method

WARNING

- ① Please confirm the product specification and read wiring method carefully before wiring.
- ② The color of connector pins and cable conductors must be checked when wiring. Check wire color with handling precaution, since improper wire connection leads to destruction/failure and malfunction.
- ③ Do not use power voltage exceeding specifications. The product could malfunction or catch fire if voltage exceeding the working range is applied.
- ④ Short-circuiting the load could result in rupture or fire.
- ⑤ The connection between the cable plug and the wire is weak. Excessive bending may shorten the life of the plug set, causing breakage or damage.

Connect the cable to the connector on the body with arranged as shown next page.

Wiring method

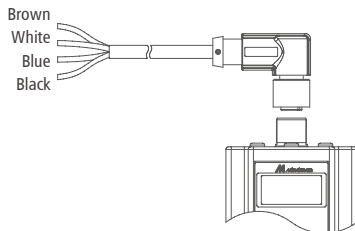
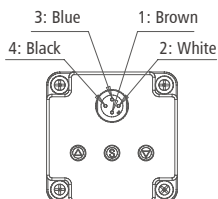

► **Input signal — Current / Voltage type**

1	Brown	Power supply
2	White	Input signal
3	Blue	GND(COMMON)
4	Black	Monitor output

► **Input signal — Preset input type**

1	Brown	Power supply
2	White	Input signal 1
3	Blue	GND(COMMON)
4	Black	Input signal 2

CAUTION

The cables are available in both straight type and right angle type. A right angle type connector is attached facing left (towards the SUP port). The direction of the straight type arrow is aligned with socket latch.

Wiring diagram (Power supply and input signal)

► **Current / Voltage type — Power supply 24VDC**

Input signal	Model
4~20mA DC	MAER200-*.*.1*
0~10VDC	MAER200-*.*.2*
0~5VDC	MAER200-*.*.3*

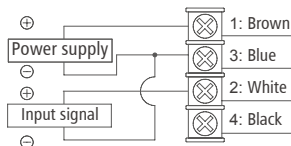

► **Preset input type — Power supply 24VDC**

Preset pressure	P_1	P_2	P_3	P_4
S1	OFF	ON	OFF	ON
S2	OFF	OFF	ON	ON

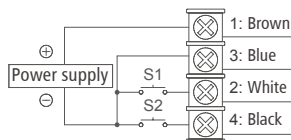

Wiring method

Wiring diagram (Monitor output)

WARNING

When the monitor output is not being used, prevent it from touching the other wires as this can cause a malfunction.

▶ Analog output · Voltage type

(MAER200-**-**1)

Please select a device with a load impedance greater than $1\text{K}\Omega$

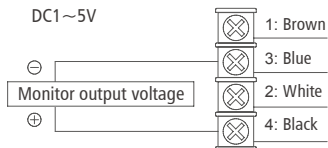

▶ Analog output · Current type (source type)

(MAER200-**-**4)

Please select a device with a load impedance less than 750Ω

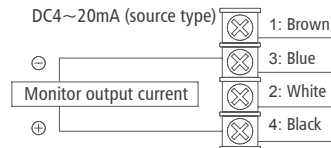

▶ Switch output · NPN type

(MAER200-**-**2)

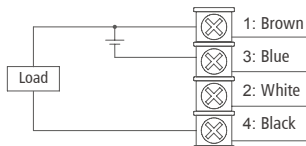

▶ Switch output · PNP type

(MAER200-**-**3)

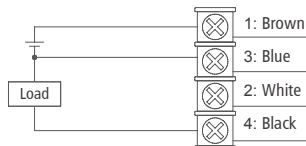

When a current of approx. 125mA DC or more is applied, the over current is archived, "Er6" is displayed and the operation stops. Please turn off power supply and check the cause of overload current or lower the current load under 125mA, and then restart the power supply.

Setting method

⚠ CAUTION

- ① It is recommended that the settings are changed without supply pressure.
- ② Please refer to each content about operation method.
- ③ The professional setting mode must be operated by people with professional knowledge and practical experience.
- ④ Improper operation of the setting mode may cause malfunction or performance loss.

Display	Symbols description of professional setting
uP / dn	Basic energizing time of increase / decrease pressure valve.
SuP / Sdn	The additional energizing time of increase / decrease pressure valve due to the switching action. It only acts for a short time when triggered.

Flow of the setting

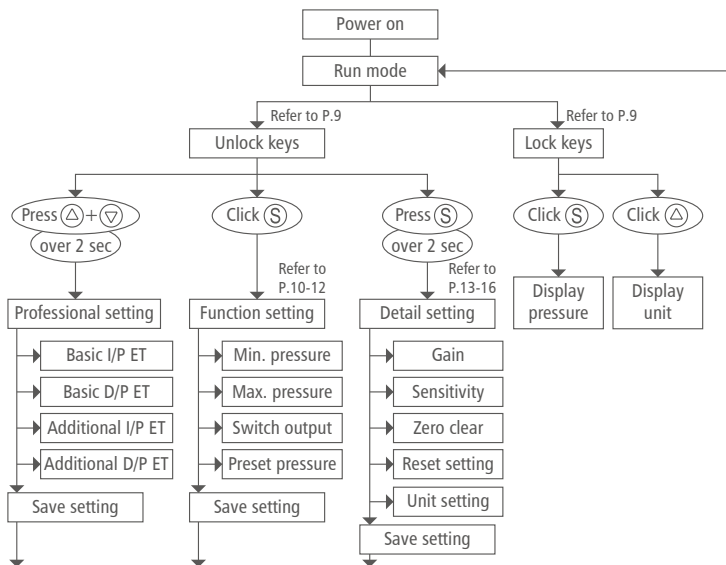

ET: Energizing time; I/P: Increase Pressure; D/P: Decrease Pressure

Error indicating function

CAUTION

Be sure to confirm the product specification and the following items before use.

- ① Please confirm that the supply pressure is correct.
- ② Please confirm that the power supply and input signal is correct.
- ③ Despite the error indication function, this product may malfunction if the power or signal exceeds the specification range.

Display	Contents of error	Countermeasure
Er 1	Input signal exceeds the rated value range	Check controller power specifications, set power voltage and input signal within the rated range, and turn power ON again. Caution: This product has this error indication function, but the input is too large or not specified, it may cause direct burnout or malfunction. Please confirm the specifications before use.
Er 2	Reading or writing errors occurred in EEPROM	Please contact us when MAER do not operate normally after restarting the power supply.
Er 3	Output pressure did not reach the set value for ten seconds or more consecutively	<ol style="list-style-type: none"> 1. Check the supply pressure within the rated range. 2. Check that there is no leakage from the pipes, fittings, or other components, correctly connect the pipes and turn on the power again. 3. Try increasing the gain value to improve the situation. If you restart the power supply after the above method, you still cannot improve the situation. Contact your nearest Mindman sales office or distributor.
Er 4	Error occurred setting the range of the min. and max. pressure	Wait three seconds or press any key to return setting.
Er 5	Out of range error of zero clear	Please operate "zero clear" after the secondary pressure of MAER is became to atmosphere. Please operate "zero clear" within the range of 5%F.S..
Er 6	Over current errors in switch output	Please turn off power supply and check the cause of overload current or lower the current load under 125mA, and then restart the power supply.

Key locking function

Function introduce

This product has key locking function. Please operate unlocking the keys before adjusting the setting data. Please operate locking the keys to return RUN mode after finish setting.

► Unlocking the keys

In RUN mode, press ∇ for more than 2 seconds.

► Locking the key

In RUN mode and unlocking, press \triangle for more than 2 seconds, and then press \textcircled{S} to return RUN mode.

Operation flow

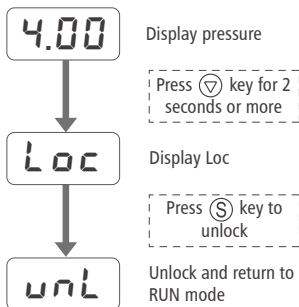

Operation flow

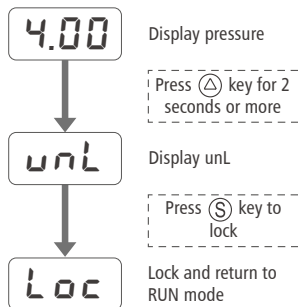

Setting linearity of output pressure to input signal

Function introduce

Set the minimum and maximum value of output pressure corresponding to the input signal.

Note: This function is current input and voltage input type only.

The adjustment like making the relation of $F_1 > F_2$ is not available. If you try doing, an error ER4 will be indicated. You must be return to set F_1 and F_2 .

F_1 is adjustable in range from 0% to 50% of the rated value. (DEFAULT VALUE: 0%)

F_2 is adjustable in range from 10% to 100% of the rated value. (DEFAULT VALUE: 100%)

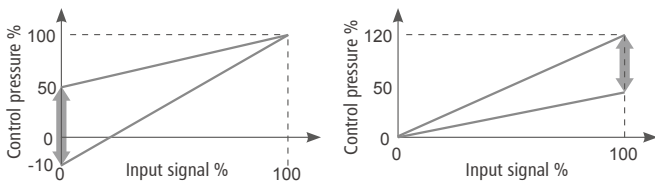

Operation flow

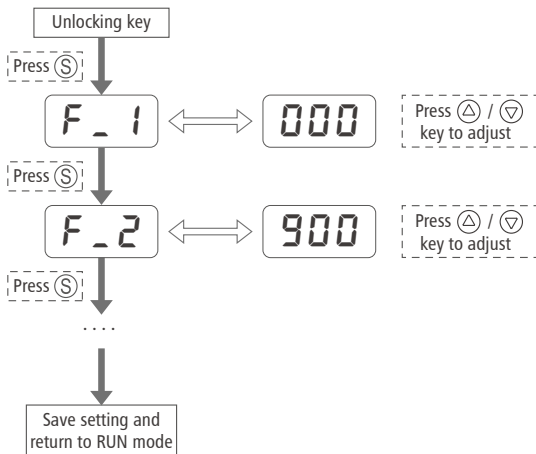

Mode of switch output

Function introduce

Switching the Window comparator mode or the Hysteresis mode according to the needs of the users.

Note: Only NPN/PNP switch output type has this function. (MAER200-**-*2, MAER200-**-*3)

The adjustment like making the relation of $P_1 > P_2$ is not available. If you try doing, an error Er4 will be indicated. You must be return to set P_1 and P_2.

▶ Window comparator mode

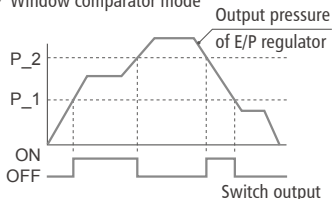

▶ Hysteresis mode

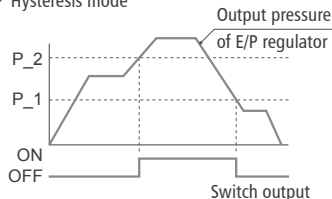

Operation flow

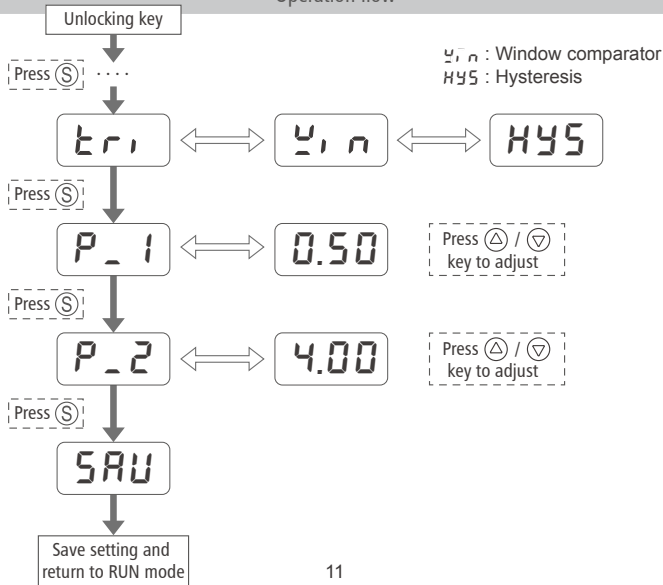

Setting of preset pressure

Function introduce

Four preset operating pressures (P_1~P_4) can be set according to customer requirements.

Note: P_1 to P_4 are adjustable within the setting pressure range.

One of the preset pressures P_1 through P_4 is selected by the ON/OFF combination of S1 and S2.

► Preset pressure and switch

Preset pressure	P_1	P_2	P_3	P_4
S1	OFF	ON	OFF	ON
S2	OFF	OFF	ON	ON

Operation flow

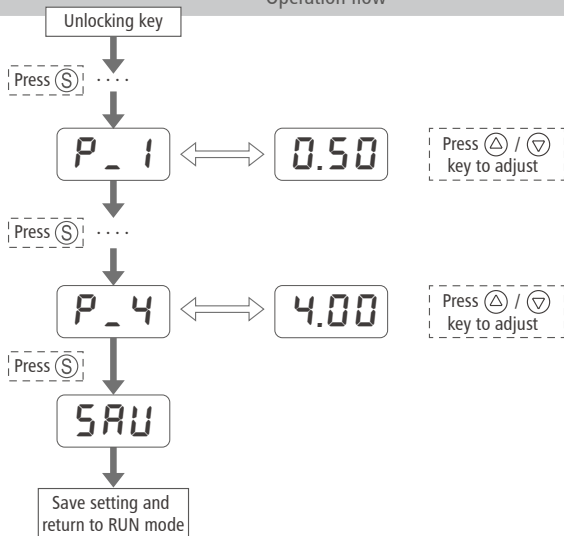

Detail setting mode

Function introduce

After Unlocking, enter the Detail setting mode to adjust the parameters.

Detail setting mode: Gain, Sensitivity, Reset, Zero clear and Unit setting. Please refer to the following instructions to operate.

Operation flow

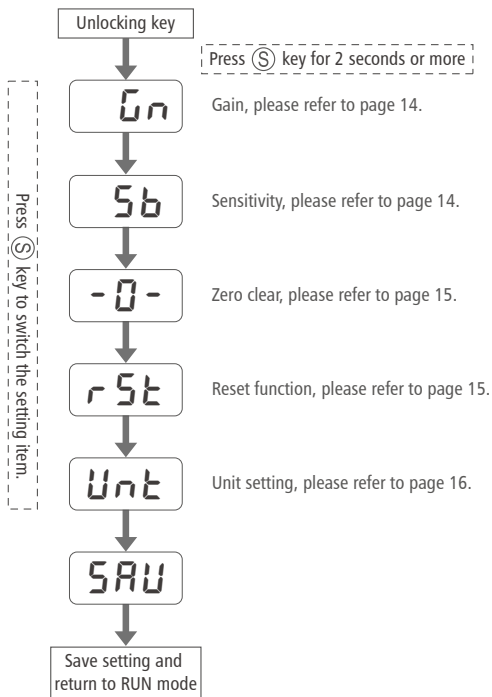

Zero clear function

Function introduce

Operating the Zero clear function can set displayed pressure to zero again. Pressure varies in different areas due to altitude differences, so pressure zeroing must be set.

Caution:

- ① Operate the Zero clear function after changing the outlet pressure to atmosphere pressure.
- ② The adjustable range of the Zero clear function is 5% F.S.. When more than this range, ER5 is displayed. Please change the outlet pressure and return the setting.

Reset function

Function introduce

Operate the Reset function can reset the pressure linearity and switch output.

Note: Gain (Gn), Sensitivity(Sb), and Unit(Unt) will not be reset. .

Operation flow

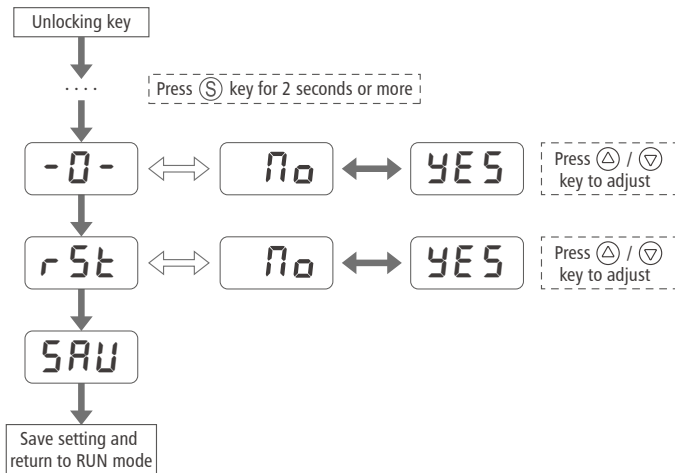

Unit setting function

Function introduce

Select pressure unit according to customer requirements.

Note: Limited to the minimum display unit, there may be numerical deviations in unit exchange. Please use linearity pressure setting to modify. Linearity pressure setting refer to page 10.

Caution:

The pressure unit is set according to the order specification before leaving the factory. If you operate the function to change unit, the product will be inconsistent with the label content.

► Pressure unit

Unit	kgf/cm ²	bar	Psi	MPa	kPa
Min. display unit	0.01	0.01	0.1	0.001	1

Operation flow

